



CK4220

42 HP



CK4220 TRACTOR

Powerfully built. Powerfully comfortable.

The CK4220 tractor - proof you can work hard around your land and still be surrounded by comfort and style. You and your land deserve it.

Eco-Friendly Diesel Engine

Dual Rear Remote Valve

Single Lever Joystick

HST Transmission

Factory-Installed Cab

Premium Features



* All product images are for illustrative purposes only and may differ from the actual product.

CK4220 STRENGTH AND COMFORT IN ONE MACHINE



Standard Front & Rear Wipers

The front and rear window wipers ensure the clear visibility by keeping the window clean from rain, dust or condensation. Wipers are positioned to minimize the impact on operator's view.



Independent PTO Switch

The standard rear Independent PTO is easily engaged by the simple turn of a knob. A safety interlock prevents the engine from starting if the PTO switch is left on. All models come standard with a selectable manual or automatic PTO option. When the Auto PTO is engaged, the PTO will automatically shut off when the 3-point control is raised, eliminating exposure to the running implements.



Single Lever Joystick

Front end loader work is made easier by the use of a single lever joystick. The lever returns to neutral when released. A float position allows the bucket free flotation over the ground surface.

Panoramic Cab View

The large unobstructed windows provide a panoramic view for increased sight lines.



Powerful Eco Friendly Engine

The Powerful Environmentally Friendly Engine will offer a quiet, smooth running and powerful performance.



Illuminated Dashboard

The illuminated dashboard ensures great visibility while working in bright daylight or at night.



Power Steering with Tilt

The standard power steering minimizes the effort required to make tight, repetitive turns. The steering wheel tilts to adjust for operator needs.



Auto PTO

CK4220 comes standard with a selectable manual or automatic PTO option. When the Auto PTO is engaged, the PTO will automatically shut off when the 3-point control is raised, eliminating exposure to the running implements.



HST Transmission

CK4220 delivers power and efficiency with all models featuring performance proven transmissions. The three range HST transmission (Hi/Mid/Low) with twin pedal operation makes your job easier, smoother and safer.



HST Linked Pedal

When the HST linked pedal is engaged, the HST pedal and the engine rpm are synchronized. As the forward or reverse pedal is depressed, engine RPM's increase to provide more torque for increased load. This reduces fuel consumption and simplifies tractor operation for a variety of utility and loader applications. Only available on HST models.



Deluxe Suspension Seat

The ergonomically designed, adjustable suspension seat allows the operator to ride in comfort no matter what the task maybe.

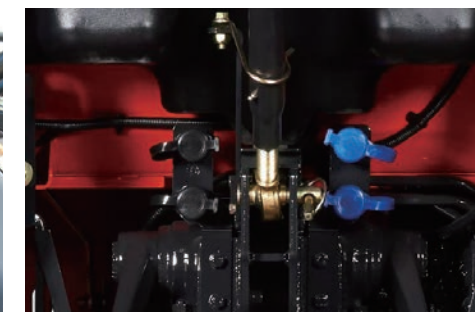

Dual Rear Remote Valves

CK4220 comes standard with dual remote hydraulic valves to accommodate a wide variety of implements.



Rear 3 Point Control Lever

It come with a standard rear 3-point lever to easily raise and lower the lift arms from outside the tractor when attaching implements.



KIOTI TRACTOR PREMIUM CK CAB SERIES



Front End Loader

KIOTI KL4010 front end loader is specifically designed for the CK Series, providing efficient performance with single lever joystick control and a dual lever quick attach bucket. The loader is designed to be quickly and easily attached and detached with the assistance of a built-in parking stand. KL loader series utilizes the tractor's hydraulic system, single-lever control with float and it comes with a bucket level indicator.

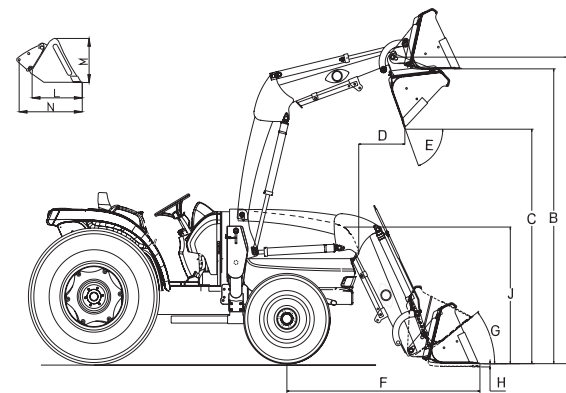

Loader Specification

MODEL	KL4010
A Maximum Lift Height to Pivot Pin	98.4 in. (2,500 mm)
B Clearance w/ Bucket Level	93 in. (2,360 mm)
C Clearance w/ Bucket Dumped	79.1 in. (2,010 mm)
D Reach at Maximum Height (45°)	27.2 in. (690 mm)
E Maximum Dump Angle	48°
F Reach w/ Bucket on Ground	62.2 in. (1,580 mm)
G Maximum Rollback Angle	28°
H Digging Depth Below Grade	5.3 in. (135 mm)
J Overall Height in Carry Position	49.6 in. (1,260 mm)
L Bucket Depth (Inner Shell)	19.9 in. (505 mm)
M Bucket Height	20.7 in. (526 mm)
N Bucket Length (Pivot Pin)	26.9 in. (682 mm)
Lift Capacity at 59.84 in. (1,520 mm) Pivot Pin Height	1,835 lbs. (832 kg)
Breakout Force at Pivot Pins	3,464 lbs. (1,571 kg)
Relief Valve Setting (Loader Control Valve)	2,560 psi
Rated Flow (Tractor System)	6.9 gpm (26.12 L/min)
Bucket Size(s) Available (QA)	60 in. / 66 in.
Approximate Weight (With Bucket)	60 in.: 959 lbs. (435 kg) / 66 in.: 981 lbs. (445 kg)
Bucket Capacity (Heaped)	60 in.: 9.39 cu. ft. / 66 in.: 10.10 cu. ft.
Bucket Rollback Force at Ground Line	1,763.7 lbs. (800 kg)

* Specifications and design are subject to change without notice.

Backhoe

The KIOTI KB2475L backhoe lets you trench up to 2,280mm deep with a bucket dig force up to 1,278 kg. The KB2475L backhoe features subframe mounting, responsive two-lever controls with exceptional feathering, hydraulic stabilizers, transport lock and a variety of standard and heavy-duty buckets.

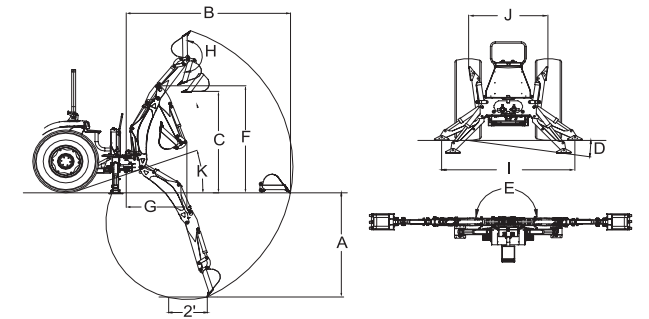

Backhoe Specifications

MODEL	KB2475L
A Digging Depth (Two Foot Flat Bottom)	89.7 in. (2,280 mm)
B Reach from Center Line of Swing Pivot	125.1 in. (3,180 mm)
C Loading Height (Bucket at 60°)	72.4 in. (1,840 mm)
D Maximum Leveling Angle	10°
E Swing Arc	180°
F Transport Height (Maximum)	83.5 in. (2,120 mm)
G Transport Overhang	49 in. (1,245 mm)
H Bucket Rotation	180°
I Stabilizer Spread (Down Position)	68.7 in. (1,745 mm)
J Stabilizer Spread (Up Position)	46.4 in. (1,180 mm)
K Angle of Departure	21°
Shipping Weight (Without Bucket)	880 lbs. (399 kg)
Bucket Digging Force	2,817.5 lbs. (1,278 kg)
Dipperstick Digging Force	2,105 lbs. (955 kg)
Operating Pressure	2,466 psi (170 bar)

Cylinders

Cylinder	Bore DIA	Retracted Length	Stroke	Rod DIA
Boom	2.75	24.41	15.12	1.57
Bucket	2.36	21.06	11.77	1.38
Dipperstick	2.75	23.5	14.84	1.57
Swing	2.36	15.67	8.78	1.38
Stabilizer	2.36	17.56	10.32	1.38

Bucket Sizes

Bucket	Teeth Quantity	Struck Capacity	Heaped Capacity	Shipping Weight
9" Bucket	3	0.73 cu. ft.	0.87 cu. ft.	46 lbs.
12" Bucket	3	1.01 cu. ft.	1.24 cu. ft.	56 lbs.
16" Bucket	3	1.38 cu. ft.	1.76 cu. ft.	64 lbs.
18" Bucket	4	1.56 cu. ft.	2.02 cu. ft.	70 lbs.
24" Bucket	5	2.11 cu. ft.	2.82 cu. ft.	94 lbs.
36" Bucket	6	2.78 cu. ft.	4.00 cu. ft.	114 lbs.

* Specifications and design are subject to change without notice.



ISO 9001
NO.954596



ISO 14001
NO.771475



OHSAS 18001
NO.K033008

SPECIFICATIONS

MODEL		CK4220 C HST	
ENGINE			
Model		3B183LWH-A	
Type		3 Cyl., In-line Vertical, Water-cooled 4-cycle diesel engine	
Engine Max	hp	42hp @ 2800 rpm	
Engine Gross	hp	38	
Rated Revolution	rpm	2,600	
Displacement	cc	1,826	
Fuel Tank Capacity	L	34	
DRIVE TRAIN			
Transmission		HST	
Speeds		3 range	
Differential Lock		Rear Standard	
Brake		Wet Disc	
PTO Type		Independent	
Rear PTO (Standard)	rpm	540	
Mid PTO (Optional)	rpm	2,000	
4WD Type		Mechanically Actuated	
HYDRAULIC SYSTEM			
Pump		Gear	
Pump Capacity (Max. Flow Rate)	L/min	42.9	
3-Point Hitch		Category I	
Max Lifting Capacity (600mm aft. of hitch)	kg	740	
Hydraulic Lift Control System		Position	
Number of Remote Valves		2 Std. (4 ports)	
Steering		Hydrostatic Power Steering	
TIRE SIZE			
Front Industrial (AG, Turf)		25×8.5-14 (7-16, 27×8.5-15)	
Rear Industrial (AG, Turf)		15-19.5 (11.2-24, 41×14-20)	
TRAVELING SPEEDS			
Forward	km/h	0 ~ 24.44	
Reverse	km/h	0 ~ 16.62	
DIMENSIONS			
Overall Length (Includes 3-pt Hitch)	mm	3,070	
Overall Width (Minimum Tread)	mm	1,385	
Overall Height (with Ind. Tires)	mm	2,315	
Wheelbase	mm	1,670	
Min. Ground Clearance	mm	340	
Tread	Front (AG.)	mm	1,225
	Rear (AG.)	mm	1,210
Min. Turning Radius (with brake)	mm	2,450	
Weight (with Ind. Tires)	kg	1,513	

STANDARD EQUIPMENT

- 4WD
- Rear PTO
- Joystick Valve
- Horn
- Head Lamp
- Signal Lamp
- Fuel Tank Cap
- PTO Cover
- Linked Pedal

OPTIONAL EQUIPMENT

- Mid PTO
- Front Weight
- Rear Weight
- Rear View Mirror
- 7 Pin Socket
- Rear Work Light
- Sun Canopy
- Front Grille Guard
- HST Cruise Control

* NOTE : Specifications and design are subject to change without notice.



**KiotiTractor/
DaedongIndustrial. Co., Ltd.**
2493, Nambusunhwan-ro, Seocho-gu, Seoul, Korea
Tel 82-2-3470-7454~9 Fax 82-2-3470-7485
www.daedong.co.kr

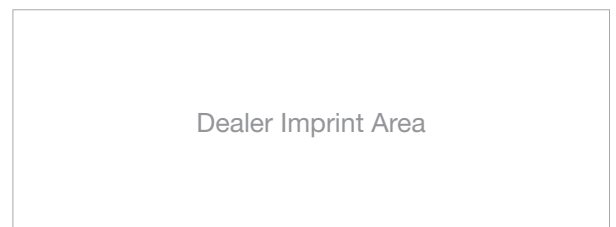

Dealer Imprint Area

LIT-CK4220-ALL1